

# INSTRUCTIONS (使用说明书)

## Pressure Control series PSV01/PSV50/PSV60/PSV15/PSV16

压力控制器一般用于制冷和空调系统，也可以用于水处理系统、锅炉系统及机床加工冷却系统等的气液循环系统，维持压力提供信号，在制冷系统中，主要安装在用于压缩机的高低压保护、冷凝器风机的高压控制、蒸发器风机的低压控制以及系统中对压力有明确要求的位置场合等。

Pressure switches apply for refrigerant and air-conditional system. It also can used for water treatment system, boiler system, Machine tool processing cooling system and the air-liquid circulation system for keeping pressure and submitting signal. During refrigerant system, mainly install for somewhere required for pressure as compressor high and lower pressure protection, high pressure control for condensor fan, the low pressure control for evaporator. Main function

适用制冷剂: R134a, R404A/R507, R407C, R22, R407A/F, R448A/449A, R452A, R513A, R450A. R410A - 仅 PSV60/16 系列; 对于未规定的冷媒, 最好不要擅自使用, 以免影响系统功能的发挥.

Refrigerant: R134a, R404A/R507, R407C, R22, R407A/F, R448A/449A, R452A, R513A, R450A. R410A - for PSV60/16; for the unspecified refrigerant, can't presume to use it So as not to affect the function of the system.



### 温度及安装要求/Temperatures and Mounting requirements

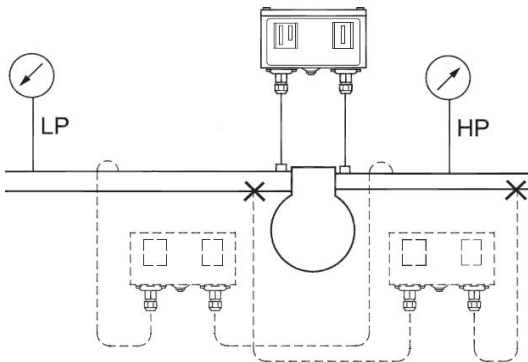

环境温度 TS Ambient: -30°C ... +65°C (-22°F...149°F)

介质温度 TS Fluid: -40°C ... +120°C (-40°F...+248°F)

### 连接方式/Connections

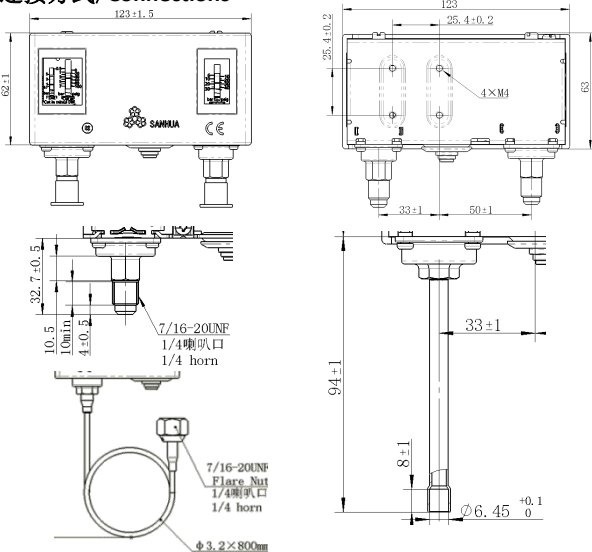

接头连接方式可根据客户要求提供，接头配备防尘帽，防止异物进入感压部件，导致进气口堵塞，影响产品动作性能。

The connection mode of joint can be provided according to customer's requirement. The joint is equipped with a dustproof cap to prevent foreign matter from entering the pressure sensitive component, which leads to the blockage of the air inlet and affects the performance.

毛细管式 can be customized to add a depressor pin  
毛细管式可定制增加顶针

### 认证/Approvals

CE-marked in accordance with:

-LVD 2014/35/EU (EN 60730-1, EN 60730-2-6);

PED 2014/68/EU, category IV (EN 12263);

Underwriters Laboratories Inc., UL listed.

### 最大工作压力和测试压力/Max. working pressure (PS/MWP) and test pressure (PT)

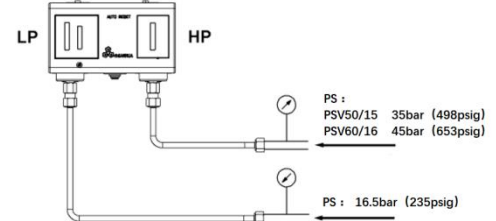

系列 Series	类型 Type	压力范围 Range	最大工作压力 Maximum working pressure/ PS/MWP	耐压测试压力 Test pressure/PT
PSV01	LP	-0.5...7bar	16.5bar/235psig	24bar/341psig
PSV50	HP	6...32bar	35bar/498psig	50bar/711psig
PSV60	HP	8...42bar	45bar/653psig	64bar/933psig
PSV15	LP	-0.5...7bar	16.5bar/235psig	24bar/341psig
	HP	6...32bar	35bar/498psig	50bar/711psig
PSV16	LP	-0.5...7bar	16.5bar/235psig	24bar/341psig
	HP	8...42bar	45bar/653psig	64bar/933psig

### 安装方式/Mounting

#### 螺纹式 Flare connection

尺寸/size	上紧扭矩 Torque
7/16-20UNF	12.7...16.7 Nm/9.37...12.32 lbf.ft

将压力控制器连接管路时,若您购买的是螺纹连接式,需要用两个扳手,分别置于接管螺母与连接管路,按表推荐的扭矩上紧。

To connect the pressure controller to the piping:if the connection is selected, use two wrenches together to tight the flare but and piping with the recommended torque in table.

不要使用一个扳手,否则可能会对产品内部造成破坏。  
Don't just use one wrench, otherwise, you may damage the internal parts of the product.

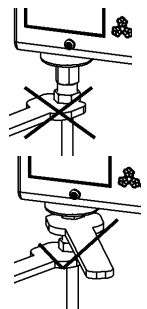

#### 焊接式 Solder connection

若您购买的是接管焊接式,焊接材料采用特定的合金(推荐 Sil-Fos 15),请勿让控制器直接接触火焰,请勿超过最大允许温度。

If the solder connection is selected, please use specific alloy for brazing(recommend Sil-Fos 15), don't point the fire torch towards the product and please limit the max temperature as shown.

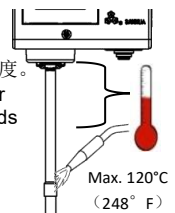

#### 毛细管式 Capillary Connection



若您购买的是带毛细管的型号,请直接将毛细管的喇叭口与系统管路连接

If the capillary connection is selected, you can connect the end directly to the piping.

#### 外盖安装 Cover installation

尺寸/size	上紧扭矩 Torque
ST2.9	0.45...0.55 Nm 0.33...0.41 lbf.ft

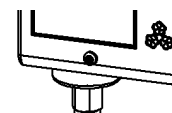

# INSTRUCTIONS (使用说明书)

## 配件/ Accessories

安装支架/Mounting plate

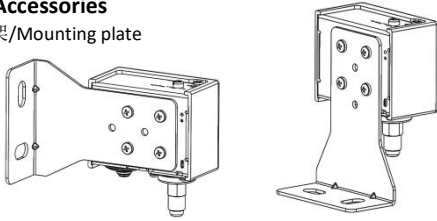

可使用 M4×0.7-6g 的螺钉固定到系统上或者使用产品定制的三花多功能安装板安装 (需额外采购)。

To mount the pressure controller to the system or use 4pcs of M4×0.7-6g screws or use SANHUA multi-position mounting plate.

## 防护顶盖/Protection top cover

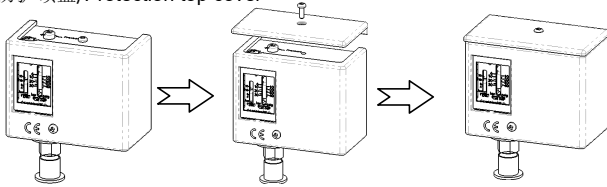

标准产品防护等级为 IP30, 可使用产品定制的三花防护顶盖附件 (需额外采购) 安装, 可达到防护等级 IP44, 拆下顶盖时, 防护等级 IP30;

Protection rating of standard product: IP30, with customizable top cover (Additional procurement required): IP44, without top cover: IP30;

## 电气参数/Electrical rating

PED 认证电气参数  
When used acc.to PED regulations.

额定电压 (V) (Rated Voltage)	AC1	AC3	AC15	DC
	400	400	400	24
额定电流 (A) (Rated Amps)	16	16	10	16

UL 认证电气参数  
When used acc.to UL regulations.

终端类型 Terminal Type	负载 Load	所需扭矩 Required Torque	线径范围 Wire Range (AWG)
负载终端 Load Terminal Block	250VAC 2HP	0.5±0.2(N.m)	14-12 (Sol/Str)
	400VAC, 16A, general use and Resistive; 125VAC 1HP	0.5±0.2(N.m)	12 (Sol/Str)
	240VAC, C300	0.5±0.2(N.m)	24-12 (Sol/Str)

## 触点系统/Contact function

低压或低压侧/  
LP=LP/LP side  
高压或高压侧/  
HP=HP/HP side

自动复位/Auto Reset  
手动复位/Manual Reset

类型/type	PSV01	PSV50/PSV60	PSV15/PSV16
自动复位/ Auto Reset	<p>LP Auto Reset</p> <p>Pressure Down</p>	<p>HP Auto Reset</p> <p>Pressure Rise</p>	<p>Auto Reset LP+HP Auto Reset</p> <p>Pressure Down Pressure Rise</p>
手动复位/ Manual Reset	<p>LP Manual Reset</p> <p>Pressure Down</p>	<p>HP Manual Reset</p> <p>Pressure Rise</p>	<p>Auto Reset LP+HP Manual Reset</p> <p>Pressure Down Pressure Rise</p>

## 低压/LP=Low Pressure

### 低压可调节压差/LP,variable ΔP

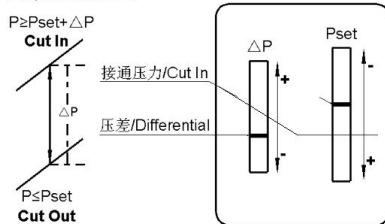

接通压力-断开压力=压差  
Cut in-Cut out=ΔP (Differential)

## 高压/HP=High Pressure

### 高压可调节压差/HP,variable ΔP

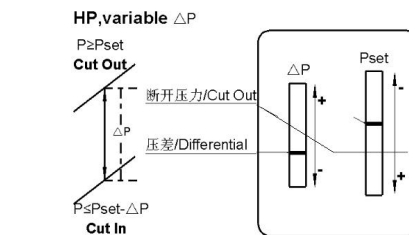

断开压力-接通压力=压差  
Cut out-Cut in=ΔP (Differential)

### 高压固定压差/HP,fixed ΔP

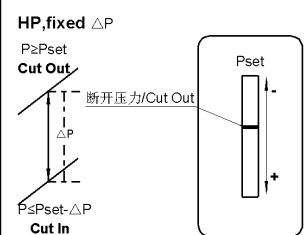

断开压力-接通压力=压差  
Cut out-Cut in=ΔP (Differential)

## 压力点调节/Set point adjustment

对系统低压侧、高压侧的断开及接通压力的设定准确度应该用精确的压力表进行检测和配合调节, 产品上设定刻度只表示近似值, 作为参考用。

The setting accuracy of Cut out pressure and Cut in pressure on the low and high side of the system should be measured and adjusted with a precise pressure gauge. The scale set on the product is an approximation only for reference.

