



“寒卫” 电子膨胀阀控制器

SEC6X1-HD 快速安装手册

II-SEC(寒卫)-MU-R2410 P02~09

SEC6x1-HD EEV Controller

Quick Installation Manual

II-SEC(HD)-MU-R2410 P10~25

“寒卫”电子膨胀阀控制器 SEC6X1-HD 快速安装手册

II-SEC(寒卫)-MU-R2410



一. 安装及接线

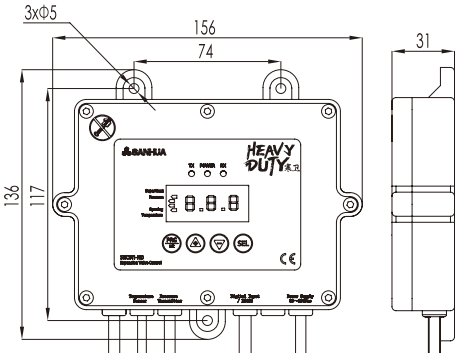

螺钉安装

通过控制器上下方共 3 个安装孔, 用 3 个 M4x6 螺钉安装。SEC6X1-HD 采用全密封设计, 可直接固定于冷风机钣金上(内外均可) 或者冷间内其他就近位置。

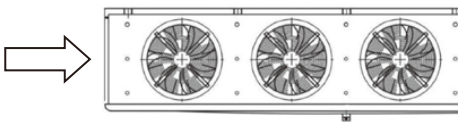

⚠ 警告 塑壳上 8 个螺钉禁止拆卸, 否则将影响产品的密封性。

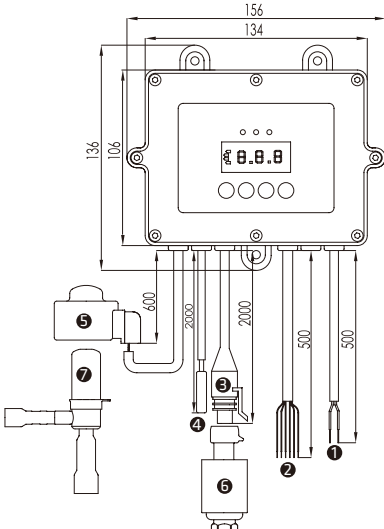

SEC611-HD(一体式线圈带压力变送器)

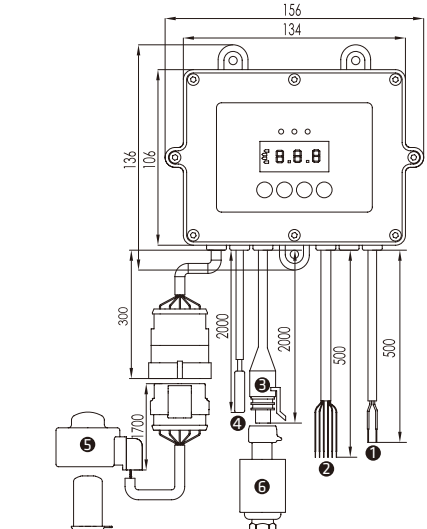

SEC621-HD(分体式线圈带压力变送器)

SEC641-HD(分体式线圈不带压力变送器)

序号	标识	名称	功能	备注	引线长度 (mm)	
					SEC611-HD/ SEC631-HD	SEC621-HD/ SEC641-HD
①	Power Supply	供电电源	L (红) N (黑)	交流 220Vac(85Vac ~ 264Vac) 50/60Hz	500	500
②	Digital Input / RS485	数字开关输入	启停 RUN (灰)	RUN 与 GND 组成开关输入	500	500
			融霜 DEF (黄)	DEFROST 与 GND 组成开关输入		
	GND (黑)	①与启停、融霜组成信号回路 ②与 12Vdc 组合给远程显示器供电				
	RS485 通讯	B (蓝) A (橙) 12Vdc(红)	R5485 B-(TRX-) R5485 A+(TRX+) 直流 12Vdc 输出			
③	Pressure Transmitter	压力变送器	5Vdc(红)	供电电源	2000	2000
			S1(白)	信号输入		
			GND(黑)	GND		
④	Temperature Sensor	温度传感器	GND(红)	/	2000	2000
			T(黑)	/		
⑤	EEV	电子膨胀阀线圈	12Vdc(灰)	单极性电子膨胀阀线圈为 5 线制。 SEC611-HD/SEC631-HD: 线圈与控制 器一体; SEC621-HD/SEC641-HD: 线圈与控制 器通过防水接头连接, 配线圈 PQ- M24012-000071。	600	2000
			\bar{B} (黑)			
			\bar{A} (黄)			
			B (红)			
			A (橙)			

注:

1. 请勿在完成接线之前接通电源, 如需更改接线请确保先切断电源。
2. 电源线接线完成后需做好绝缘和防水处理, 建议在 IP65 以上的接线盒 (图 1) 内完成接线。
3. 数字开关输入信号启停和融霜接线后需做好绝缘和防水处理, 其余不用的线建议剪去线头 (图 3) 并做好绝缘和防水处理避免短路, 建议在 IP65 以上的接线盒 (图 2) 内完成接线。
4. 启停和融霜信号无源接法请参照图 4, 有源接法请参照图 5。
5. 对 SEC611-HD/SEC621-HD 序号③压力变送器 (Packard 接头) 在本包装内, 对 SEC631-HD/SEC641-HD 序号③压力变送器 (Packard 接头) 请根据实际需求单独订购; 序号⑤电子膨胀阀阀体 (单极型) 请根据实际需求单独订购。
6. 融霜信号优先级高于启停信号; 若需开启融霜功能先接通启停信号再接通融霜信号。



图 1



图 2



图 3



图 4 无源输入接法

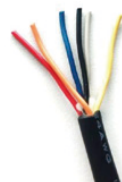

图 5 有源输入接法

远程显示器（选配）接线示意图如上所示
外形尺寸 84(W)×36(H)×19.4(D)mm
开孔尺寸 71(W)×30(H)mm

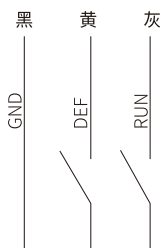
远程显示器与控制器之间的通讯电缆建议采用
双绞屏蔽线 2P×24AWG 以上

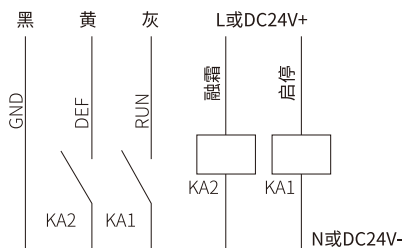
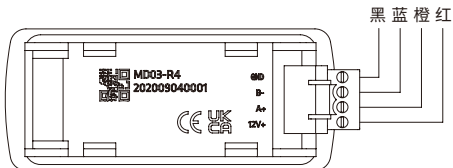

建议将温度传感器与压力变送器安装尽量靠近蒸发器
出口，距离蒸发器出口不超过 0.5m 的吸气管路上，可
防止环境温度 and 压降干扰过热的计算。

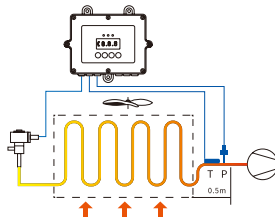

二. 按键及操作

★默认显示当前吸气过热度 SH；按【+】或【-】键可切
换显示内容，查看完其他实时数据，无按键操作 1 分钟
之后自动回归“SH”数据显示。

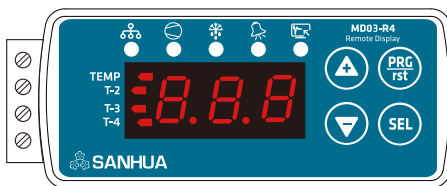

定义	描述
按钮	<ul style="list-style-type: none"> 长按进入参数设置模式或短按返回上一层 增加或上翻 减少或下翻 选择与保存

定义	描述
LED	<ul style="list-style-type: none"> 通讯正常则 LED 常亮 启停开关闭合则 LED 常亮 融霜开关闭合则 LED 常亮 有故障或保护则 LED 常亮 预留

定义	描述
LED	<ul style="list-style-type: none"> °C / bar 显示温度 / 压力的单位 ★ SH 显示当前吸气过热度 PRESS 显示当前低压力

定义	描述
LED	<ul style="list-style-type: none"> OPEN 显示当前电子膨胀阀开度 TEMP 显示吸气温度 SH +PRESS 显示吸气压力对应饱和温度

- 通电运行状态下，长按 键 3 秒以上，进入参数设置模式；
- 当面板显示 时，按 直至面板显示 5（初始密码），再 按进入参数列表；
- 表示参数表 1，按 键可选择 、.....（切换参数表）；
- 选定参数表后按 进入参数表，如想切换其他参数表，按 返回参数表选择界面；
- 进入参数表后，面板直接显示参数代码，按 可在不同代码之间顺序切换；
- 当面板显示想要修改参数的代码时，按 可直接修改参数，按 显示下一个参数或按 返回参数列表；

g. 修改完所有参数后，长按 **PRG/FRT** 3 秒保存设置，此时数码管显示“---”，1 秒后，自动返回正常运行界面。

备注：

1. 如果密码输入错误或者没有输入密码，则可以进行参数查询，但不能进行参数更改；
2. 输入密码正确进入参数设置后，10 分钟内可以进行参数设置，10 分钟后须重新输入密码；进入参数设置操作后，若 3 分钟内无操作则自动退出到正常运行显示界面。

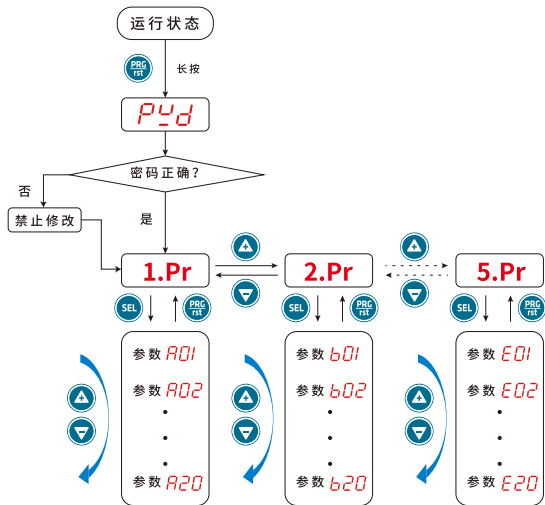

三. 主要参数设置

3.1 控制器模式选择

地址 (代码)	工作模式	设定数值	描述	接线
40057 (C16)	控制模式 0	0	- 过热度自动控制模式 - 温度/压力信号确保过热度稳定	
40057 (C16)	控制模式 1	1	- 阀门手动控制模式 - 通过面板 ▲▼ 按钮直接控制阀门开度比例	
40057 (C16)	控制模式 2	2	- 驱动模式 - (1-5)V 外接模拟信号来驱动	
40057 (C16)	控制模式 3	3	- 温度控制模式 - 通过设定目标温度，接收温度传感器检测的温度来控制阀门开度	

注 1. 使用手动控制 / 驱动模式时，请保持启停信号 RUN 常通。
2. 使用驱动模式时，外接 (1-5)V 外接模拟信号通过压力变送器输入。

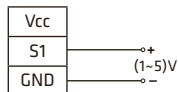

3.2 制冷剂选择

位于参数表 4.P_r 中

地址	代码	描述	默认值		范围
40062	d01	制冷剂选择	5(R507)	14(R744-CO ₂)	-1 ~ 35



注：对于 SEC611-HD 和 SEC621-HD,d01 默认值为 5(R507)；对于 SEC631-HD 和 SEC641-HD,d01 默认值为 14(R744-CO₂)。

目前控制器中有 36 种常用制冷剂可供选择

代码	制冷剂	代码	制冷剂	代码	制冷剂	代码	制冷剂	代码	制冷剂
-1(OFF)	自定义	7	R1234yf	15	R744A(N ₂ O)	23	R407H	31	R1270
0	R22	8	R290	16	R32	24	R454C	32	R1233zd(E)
1	R404A	9	R450A	17	R245fa	25	R455A	33	R1234ze(Z)
2	R410A	10	R513A	18	R23	26	R454B	34	R452C
3	R134A	11	R448A	19	R407A	27	R452B	35	R457A
4	R407C	12	R449A	20	R407F	28	R600a		
5	R507	13	R452A	21	R124	29	R600		
6	R1234ze(E)	14	R744(CO ₂)	22	R717	30	R454A		

3.3 恢复出厂设置

地址	代码	描述	默认值	范围
40080	d19	恢复出厂设置	0	0 ~ 999

恢复出厂设置选项位于 4.P_r 菜单中，在参数设置状态下，按  找到参数 d19，输入密码或备用密码 913 并点击  恢复出厂设置，并重新复位运行。

四. 参数表

4.1 表 1.P_r

地址	描述	代码	单位	间隔	Min.	Max.	默认值	
40001	温度 / 过热度设定值	R00	K	0.1	0.5	30.0	6.0	
40003	开机初始开度	R02	%	1	0	100	40	
40004	初始开度持续时间	R03	秒	1	0	600	10	
40005	P: 比例增益	R04	%	0.1	0.1	99.9	1.0	
40006	I: 积分时间	R05	sec	1	0	999	50	
40007	D: 微分时间	R06	sec	1	0	999	30	
40008	低过热度报警模式	R07	0= 不启用 1= 自动复位				0	
40009	低过热度报警值	R08	K	0.1	0.5	30.0	0.5	
40010	低过热度报警延迟时间 / 秒	R09	sec	1	1	300	15	
40011	取消低过热度报警	R10	K	0.1	1	30.5	3.0	
40012	MoP 报警模式 ¹⁾	R11	0= 不启用 1= 自动复位				1	0
40013	MoP 报警值 ²⁾	R12	bar	0.1	-1.0	50.0 99.9	9.0 38.7	
40014	MoP 报警延迟时间 / 分钟	R13	min	1	1	15	1	
40015	取消 MoP 报警 ³⁾	R14	bar	0.1	-1.0	50.0 99.9	8.0 36.7	
40016	高过热度报警模式	R15	0= 不启用 1= 自动复位				0	
40017	高过热度报警值	R16	K	1	10	40	30	
40018	高过热度报警延迟时间 / 分钟	R17	min	1	1	600	3	
40019	取消高过热度报警	R18	K	1	7	37	27	
40020	MoP 关阀比例	R19	/	1	0	999	200	

- 1) SEC611-HD 和 SEC621-HD 的报警默认值为 1。SEC631-HD 和 SEC641-HD 的报警模式默认值为 0。
- 2) SEC611-HD 和 SEC621-HD 的 MoP 报警值的 Max. 和默认值分别为 50.0 和 9.0。SEC631-HD 和 SEC641-HD 的 MoP 报警值的 Max. 和默认值分别为 99.9 和 38.7。
- 3) SEC611-HD 和 SEC621-HD 的取消 MoP 报警的 Max. 和默认值分别为 50.0 和 8.0。SEC631-HD 和 SEC641-HD 的取消 MoP 报警的 Max. 和默认值分别为 99.9 和 36.7。

4.2 表 2.Pr

地址	描述	代码	单位	间隔	Min.	Max.	默认值
40021	防冰冻报警模式	b00		0= 不启用 1= 自动复位			0
40022	防冰冻报警值	b01	°C	1	-40	40	0
40023	防冰冻报警延迟时间 / 秒	b02	sec	1	5	200	30
40024	取消防冰冻报警	b03	°C	1	-37	43	3
40025	选择抽空功能和延迟时间 (预留)	b04	sec	1	-1	180	-1
40026	用于停止抽空的压力设定点 (预留)	b05	bar	0.1	-0.5	18.0	0.5
40027	低压报警模式	b06		0= 不启用 1= 自动复位			0
40028	低压报警值	b07	bar	0.1	-0.8	17.7	0
40029	低压报警延迟时间 / 秒	b08	sec	1	5	200	5
40030	清除低压报警	b09	bar	0.1	-0.5	18.0	0.3

4.3 表 3.Pr

地址	描述	代码	单位	间隔	Min.	Max.	默认值
40041	膨胀阀是否保持电流	C00		0= 关闭, 1= 有保持电流			0
40042	膨胀阀励磁模式 (须断电重启)	C01		0= (1-2 相励磁), 1= (2-2 相励磁)			0
40043	膨胀阀总步数 (须断电重启)	C02	×10PLS	1	0	999	50
40044	膨胀阀开启步数 (须断电重启)	C03	PLS	1	0	999	30
40045	膨胀阀驱动速度 (须断电重启)	C04	/	1	0	8	2
40051	融霜固定开度百分比 *	C10	%	1	0	100	80 0
40052	传感器故障时电子膨胀阀开度百分比	C11	%	1	0	100	50
40053	融霜信号控制使能	C12		0= 关 1= 开			0
40056	启停信号控制使能	C15		0= 关 1= 开			0
40057	控制模式 (须断电重启)	C16		0= 过热度自动模式 1= 阀门手动模式 2= 驱动模式 3= 温度控制模式			0
40058	融霜控制方式	C17		0= 开关量控制 1= 通讯控制			0
40059	压力变送器类型	C18		0=(0.5 ~ 3.5)V 1=(0.5 ~ 4.5)V			0

*SEC611-HD 和 SEC621-HD 的融霜固定开度百分比默认值为 80，SEC631-HD 和 SEC641-HD 的融霜固定开度百分比默认值为 0。

- 1) 因控制器显示最大值为 999，故【膨胀阀总步数】值 50 代表 500 步。
- 2) 电子膨胀阀驱动速度 10(0)=10PPS；20(1)=20PPS；30(2)=30PPS；50(3)=50PPS；80(4)=80PPS；100(5)=100PPS；200(6)=200PPS；250(7)=250PPS；500(8)=500PPS。
- 3) 地址 40052 传感器故障时电子膨胀阀开度百分比中传感器指温度传感器和压力变送器。
- 4) 地址 40053 融霜信号控制使能需与地址 40058 融霜控制方式配合使用，地址 40058 选择通讯控制时，根据地址 40053 控制融霜信号。
- 5) 地址 40056 启停信号控制使能需与地址 40077 启停控制方式配合使用，地址 40077 选择通讯控制时，根据地址 40056 控制启停信号。

4.4 表 4.Pr

地址	描述	代码	单位	间隔	Min.	Max.	默认值
40062	制冷剂 ¹⁾	d01	/	1	0	28	5 14
40063	压力变送器压力最大值 ²⁾	d02	bar	1	-1	99	20 60
40064	压力变送器压力最小值 ²⁾	d03	bar	1	-1	99	-1 0
40065	压力变送器偏移校正	d04	bar	0.1	-9.9	9.9	0
40066	温度传感器偏移校正	d05	°C	0.1	-19.9	19.9	0
40067	密码	d06	/	1	0	999	5
40070	电子膨胀阀开度最大百分比	d09	%	1	0	100	100

地址	描述	代码	单位	间隔	Min.	Max.	默认值
40071	电子膨胀阀开度最小百分比	d 10	%	1	0	100	0
40072	传感器 (压力和温度) 输入滤波时间	d 11	sec	0.1	1.0	99.9	1.0
40073	电子膨胀阀强制开阀比例	d 12	%	0.1	-1 (OFF)	100.0	-1 (OFF)
40076	显示模式	d 15	0-5, 0 表示轮流显示 1= 过热度 2= 蒸发器出口压力 3= 膨胀阀开度 4= 蒸发器出口温度 5= 饱和温度				0
40077	启停方式	d 16	0= 常开 1= 开关信号控制 2= 通讯信号控制				1
40078	MODBUS ID 设置	d 17	/	1	1	128	1
40079	通讯设置, 波特率、校验位、停止位 (须断电重启)	d 18	0=4800,NONE,1 1=9600,NONE,1 2=19200,NONE,1 3=38400,NONE,1 4=4800,NONE,2 5=9600,NONE,2 6=19200,NONE,2 7=38400,NONE,2 8=4800,EVEN,1 9=9600,EVEN,1 10=19200,EVEN,1 11=38400,EVEN,1 12=4800,EVEN,2 13=9600,EVEN,2 14=19200,EVEN,2 15=38400,EVEN,2 16=4800,ODD,1 17=9600,ODD,1 18=19200,ODD,1 19=38400,ODD,1 20=4800,ODD,2 21=9600,ODD,2 22=19200,ODD,2 23=38400,ODD,2				1(96)
40080	恢复出厂设置	d 19					0

- 1) 对于 SEC611-HD 和 SEC621-HD,d01 默认值为 5(R507); 对于 SEC631-HD 和 SEC641-HD,d01 默认值为 14(R744-CO₂)。
- 2) SEC611-HD 和 SEC621-HD 的压力变送器压力最大值和最小值的默认值分别为 20 bar 和 -1 bar; SEC631-HD 和 SEC641-HD 的压力变送器压力最大值和最小值的默认值分别为 60 bar 和 0 bar。
- 3) 地址 40073 电子膨胀阀强制开阀比例设为 -1 表示关闭强制控制电子膨胀阀, 恢复自动自动控制。
- 4) 恢复出厂设置时, 将对应参数改成密码值或 913, 点击  键后控制器重启, 恢复成功。
- 5) 恢复出厂设置时只对参数表 1.Pr ~ 4.Pr 进行恢复。

4.5 表 5.Pr

地址	描述	代码	单位	间隔	Min.	Max.	默认值
40085	吸气压力最大 AD	E04	/	1	0	999	662
40086	吸气压力最小 AD	E05	/	1	0	999	92
40092	冷媒自定义参数 A1	/	91	A1 Min -20000 Max 20000 A2 Min -20000 Max 20000 A3 Min -20000 Max 20000			(R449A) A1:9975 A2:-2020 A3:2424
40093	冷媒自定义参数 A2	/	92	当 40062 制冷剂设置为 -1 时, 开启自定义模式。			
40094	冷媒自定义参数 A3	/	93	A1、A2、A3 为自定义参数, 仅支持 485 通讯设置			

注: 如果更换了压力变送器, 需要对压力变送器最大 AD 和最小 AD 值进行重新校准。

五. 报警信息

1、当控制器报警时, 数码管报警指示灯亮, 并交替显示正常运行显示界面以及故障显示代码。

报警代码显示如下表所示:

代码	报警信息	代码	报警信息
S _t P ⁰	启停信号 RUN 断开	ñ _o P	MoP 高压过高报警
P _o P	压力变送器未连接	L _o P	LoP 低压过低报警
P _S t	压力变送器短路 (SEC611-HD/SEC621-HD) 取消 P _S t 报警 ²⁾ (SEC631-HD/SEC641-HD)	H _S H	高温 / 过热度报警
t _o P	温度传感器未连接	L _S H	低温 / 低过热度报警
t _S t	温度传感器短路	F _r E	低温冰冻报警

注: 1) 启停信号断开, 显示 S_TP 非报警, 仅作运行状态提醒, 当系统运行, RUN 启停信号线闭合后该代码消失。

2) CO₂ 的高压可能会引起 P_St 误报, 因此取消 SEC631-HD/SEC641-HD 的 P_St 报警。

2、地址 40110 报警标志位

bit	15	14	13	12	11	10	9	8	7	6	5	4	3	2	1	0
						FrE	LSH	HSH	LoP	MoP			LSL	LoP	PSt	PaP

标志位为 0 表示无故障 / 保护；标志位为 1 表示有故障 / 保护。

六. 通讯状态表

地址	功能	单位	类型	字数	SEC6X1-HD 显示	RS485 通讯
40034	当前过热度	K	模拟信号	INT 16		×10
40035	当前压力	bar	模拟信号	INT 16	-1.0 ~ 99.0	×100
40036	膨胀阀开度	%	模拟信号	INT 16	0.0 ~ 100.0	×10
40037	当前温度	°C	模拟信号	INT 16	-100.0 ~ 100.0	×10
40038	当前饱和温度	°C	模拟信号	INT 16		×10
40073	膨胀阀强制开阀比例	%	模拟信号	INT 16	-1.0 ~ 100.0	×10
40101	开关量输入状态					
Bit0	启停信号状态	-	数字信号	bit	0:STOP 1:RUN	
Bit1	融霜信号状态	-	数字信号	bit	0:OFF 1:ON	
40110	报警状态	-	模拟信号	INT 16	由后续数字信号决定	
Bit0	压力变送器未连接	-	数字信号	bit	0:OFF 1:ON	
Bit1	压力变送器短路 (SEC611-HD/SEC621-HD) 取消 PSt 报警 ²⁾ (SEC631-HD/SEC641-HD)	-	数字信号	bit	0:OFF 1:ON	
Bit2	温度传感器未连接	-	数字信号	bit	0:OFF 1:ON	
Bit3	温度传感器短路	-	数字信号	bit	0:OFF 1:ON	
Bit6	MoP 高压过高报警	-	数字信号	bit	0:OFF 1:ON	
Bit7	LoP 低压过低报警	-	数字信号	bit	0:OFF 1:ON	
Bit8	高过热度报警	-	数字信号	bit	0:OFF 1:ON	
Bit9	低过热度报警	-	数字信号	bit	0:OFF 1:ON	
Bit10	防冻冻报警	-	数字信号	bit	0:OFF 1:ON	

七. 通讯

- 1、支持标准 RS485 Modbus RTU 协议（2 线制半双工），最多 31 台级连，建议最后一个产品上并上终端电阻 120Ω。
- 2、通讯电缆需采用双绞屏蔽线，推荐 2P×24AWG，接线两端屏蔽线都要分别接地。
- 3、当上位机 ID=255 或者 ID=【d17】时，都可以实现与本控制器正常通讯。
- 4、对于通讯波特率，上电后 4 秒内，控制器按 9600bps，8，N，1 进行通讯，若能正常通讯则 4 秒后控制器按 9600bps，8，N，1 运行；若 4 秒内未能按 9600bps，8，N，1 进行通讯，则 4 秒后控制器按照【d18】设定的波特率运行。

八. 技术参数

项目	参数	项目	参数
工作电压	220Vac(85V ~ 264V) 50/60Hz 25VA	通讯方式	RS485，（默认）9600，8，N，1
开关信号	启停、融霜开关信号无源输入	防护等级	IP67
压力变送器	(0.5 ~ 3.5)Vdc 或 (0.5 ~ 4.5)Vdc，5Vdc 电源	安装方式	3 个 M4x6 螺钉
温度传感器	NTC 5KΩ(B=3970K)，-40°C ~ +105°C	工作温度	-35°C ~ 55°C
驱动负载	单极性 5 线电子膨胀阀	储存温度	-40°C ~ 60°C，相对湿度 90%，无冷凝
抗浪涌电压	II 类	环境污染等级	2
认证	CE、UKCA、EAC	绝缘等级	II
EMC 符合性	IEC61000-4-2, IEC61000-4-3, IEC61000-4-4, IEC61000-4-5, IEC61000-4-6, IEC61000-4-11		

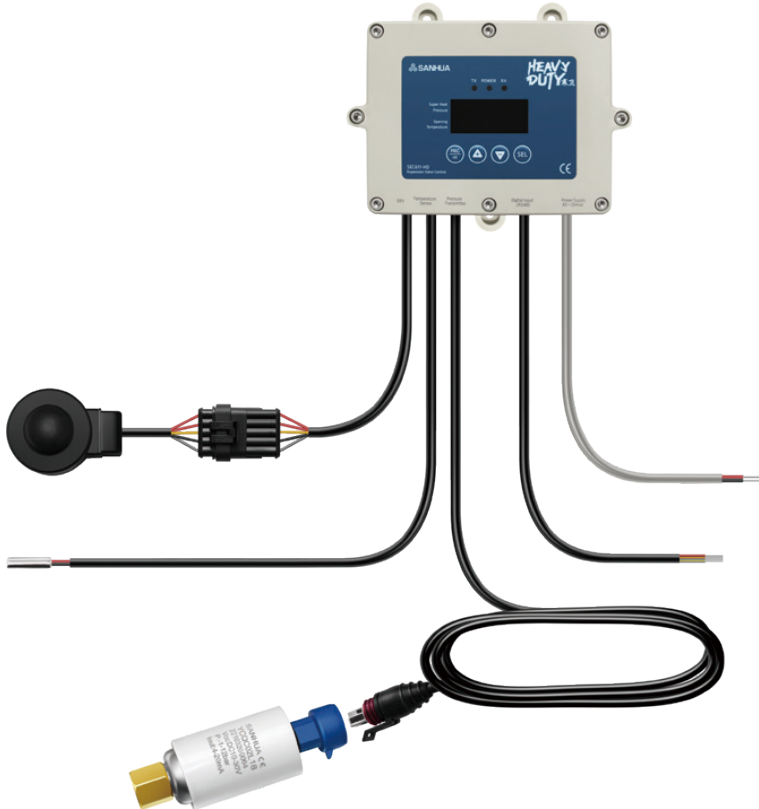

SEC6x1-HD EEV Controller

Quick Installation Manual

II-SEC(HD)-MU-R2410

1. Installation and Wiring

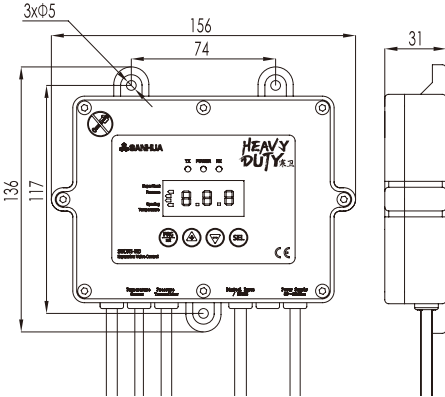

Screw installation

Use 3pcs M4x6 screws through 3 mounting holes to install controller. SEC6X1-HD has fully hermetic design and can be directly installed on the sheet metal of the air cooler (both inside and outside) or other nearby locations in the cold room.

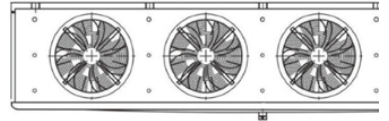

Do not remove the 8 screws on the plastic case, otherwise the sealing of the product will be affected.

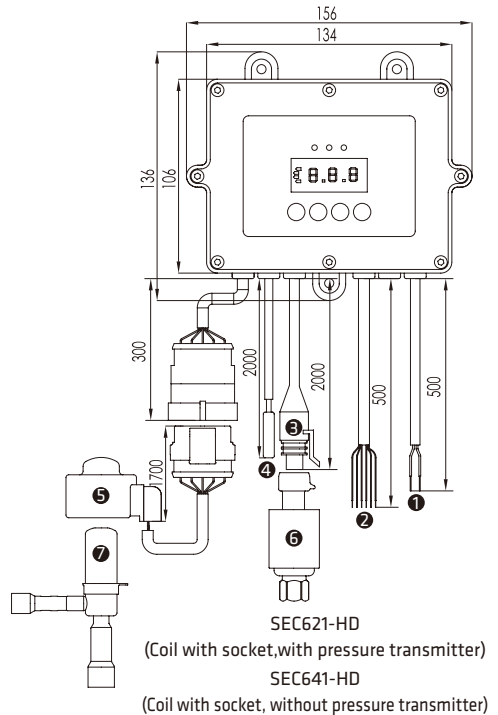
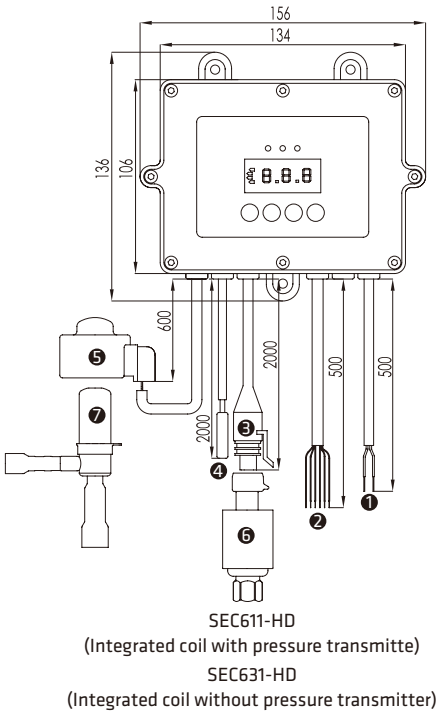

No.	Print	Description	Function	Remarks	Cable Length (mm)	
					SEC611-HD/ SEC631-HD	SEC621-HD/ SEC641-HD
①	Power Supply		L (Red)	220Vac (85Vac ~ 264Vac) 50/60Hz	500	500
			N (Black)			
②	Digital Input	Digital Input /RS485	START/STOP RUN (Grey)	Connect with GND	500	500
			Defrost DEF (Yellow)	Connect with GND		
			GND (Black)	① Connect with RUN, defrost signal to be a switch. ② Connect with 12Vdc to power the remote display.		
	RS485 Communication	B (Blue)	RS485 B- (TRX-)			
		A (Orange)	RS485 A+ (TRX+)			
		12Vdc (Red)	12Vdc output			
③	Pressure Transmitter		5Vdc (Red)	Power Supply	2000	2000
			S1 (White)	Signal input		
			GND (Black)	GND		
④	Temperature Sensor		GND (Red)	/	2000	2000
			T (Black)	/		
⑤	EEV	EEV Coil	12Vdc (Grey)	The unipolar electronic expansion valve coil is 5-wire. SEC611-HD/SEC631-HD: The coil is integrated with the controller ; SEC621-HD/SEC641-HD: Coil and controller connected by waterproof connector, with coil PQ-M24012-000071.	600	2000
			\bar{B} (Black)			
			\bar{A} (Yellow)			
			B (Red)			
			A (Orange)			

Notes:

1. Don't apply power before wiring is completed. If wiring change is needed, make sure the power is off.
2. The wiring of the power cord needs to be insulated and waterproof after completion, and it is recommended that the wiring be completed in a junction box (Figure 1) above IP65.
3. After the wiring of digital input and defrosting input good insulation and waterproof treatment are needed, the rest of the unused line is recommended to cut off the wire head (Figure 3) and good insulation and waterproof treatment to avoid short circuit, it is recommended in the IP65 or higher junction box (Figure 2) to complete the wiring.
4. Please refer to Figure 4 for passive connection method of start/stop and defrosting signal, and Figure 5 for active connection method
5. For SEC611-HD/SEC621-HD, No. ⑥ Pressure Transmitter (Packard Connector), please order within this package; For SEC631-HD/SEC641-HD, ⑥ Pressure Transmitter (Packard Connector), please order separately according to actual requirements. Please order No. ⑦ Electronic expansion valve body(unipolar) separately on demand.
6. The priority of the defrosting signal is higher than the start/stop signal; if you need to turn on the defrosting function, first turn on the start/stop signal and then turn on the defrosting signal.



Figure 1



Figure 2

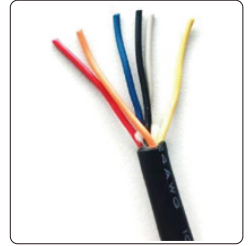

Figure 3

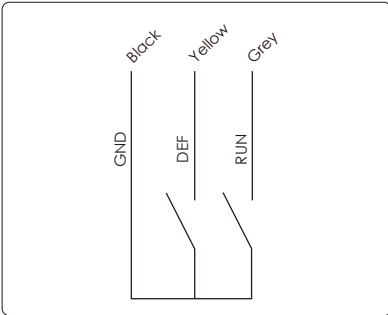

Figure 4 Passive input connection

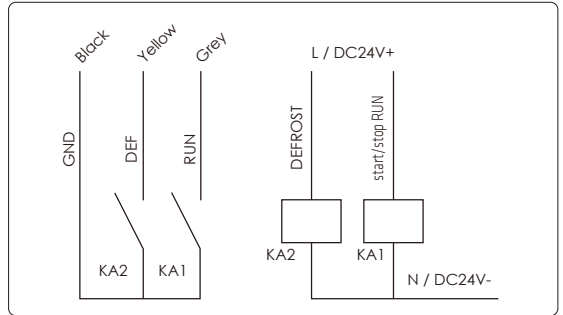

Figure 5 Active input connection

Remote display (optional) wiring diagram shown as above:

Dimension 84(W)×36(H)×19.4(D)mm

Hole size 71(W)×30(H)mm

The communication cable between the remote display and the controller recommends a twisted pair shielded above 2P×24AWG.

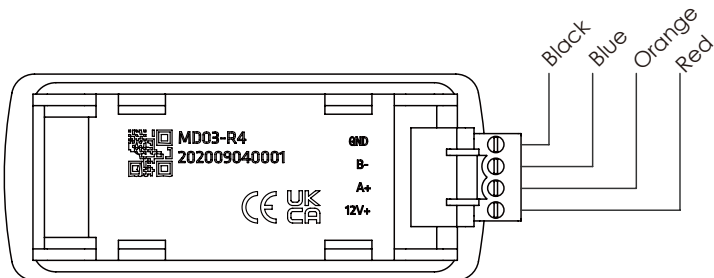

It is recommended to install the temperature sensor and pressure transmitter on the suction line within 0.5m from the outlet of the evaporator to avoid the interference of the superheat calculation from the environmental temperature and pressure drop.

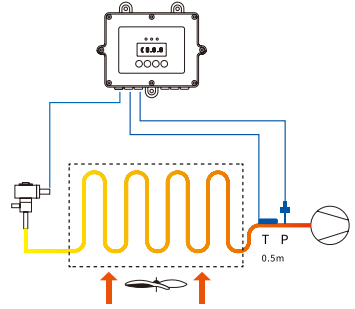

2. Button and operation

★ Default display current suction superheat SH; Press **【+】** or **【-】** to switch display content. After reading other real time data, it will automatically return to the “SH” display after 1 minute if no other key press.

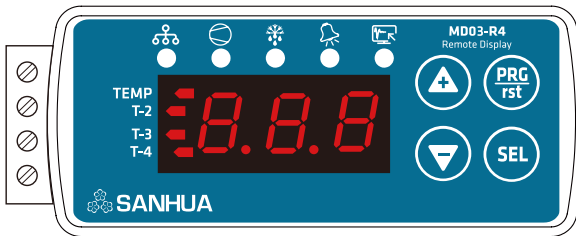







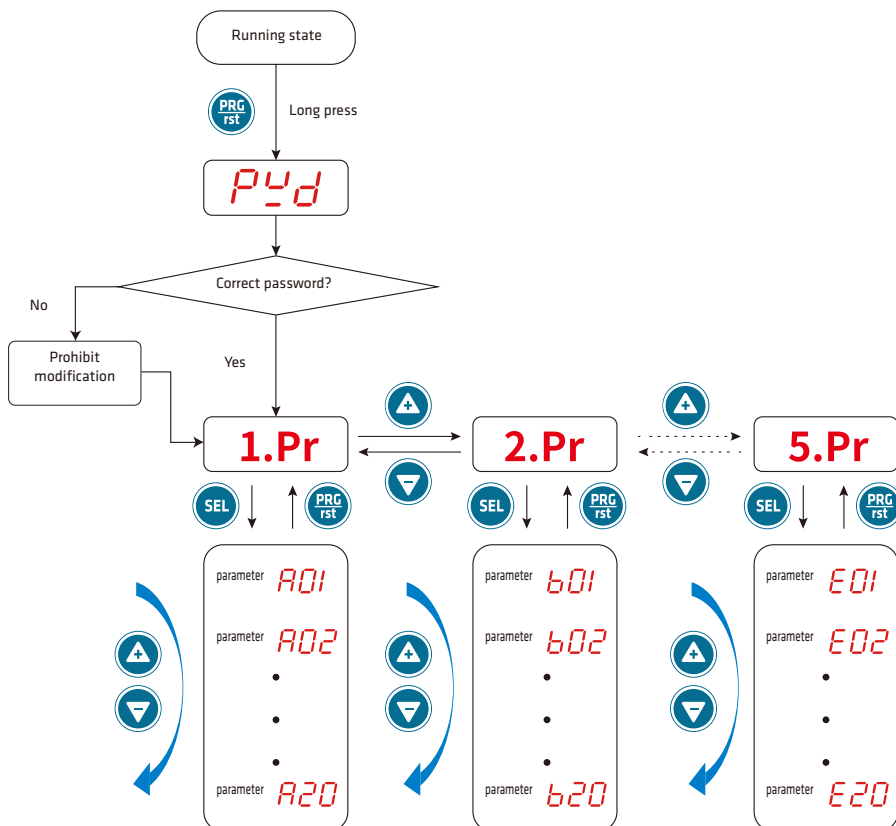





Definition	Description	
Button		Long press to enter to parameter setting mode or short press to return to previous level.
		Add or pull up
		Reduce or pull down
		Select and save

Definition	Description	
LED		LED on when communication is good.
		LED on when start/stop switch is on
		LED on when defrost switch is on
		LED on alarm or protection
		Reserved

Definition	Description		Definition	Description	
LED	°C /bar	Display temperature/ pressure unit	LED	OPEN	Display current EEV opening
	★ SH	Display current suction superheat		TEMP	Display suction temperature
	PRESS	Display current evaporating pressure		SH + PRESS	Display saturated temperature corresponding to suction pressure



- a. In the power-on state, Long press  for more than 3s, enter to parameter setting mode.
- b. When screen displays *PYd*, press  until screen shows 5 (default password), press  to enter to parameter list.
- c. *1Pr* stands for **parameter 1**, press   to select *2Pr*、*3Pr* (switch parameter list) .
- d. After selecting parameter list, press  to enter parameter list. If want to switch to other parameter list, press  to return to parameter list selection interface.
- e. After entering to parameter list, the panel directly displays parameter code, press  to switch among different codes.
- f. When the panel displays the parameter codes that should be modified, press   to directly modify parameters, press  to display next parameter or press  to return to previous parameter list.
- g. After all parameters are modified, long press  for 3s to save the settings, the digital pipe will show “---” for 1s and then automatically return to the normal operation interface.

Notes:

1. If password is incorrect or no password is entered, it is allowed to review, but not allowed to modify the parameter,
2. If password is correct and enter to parameter setting, the settings should be done in 10 minutes. After 10 minutes, you need to enter correct password to complete the settings again. If there is no any modification after entering to parameter setting, the interface will automatically exit to normal operation interface.

3. Main parameter settings

3.1 Controller mode selection

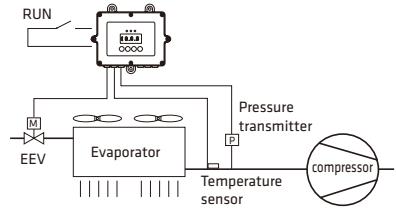
Holding Register Address (code)	Working mode	SETUP MODE	Description	Wire connection
40057 (C16)	Controlling mode 0	0	<ul style="list-style-type: none"> •Automatic superheat controlling mode •The temperature/pressure signals ensure the system superheat is stable 	

Holding Register Address (code)	Working mode	SETUP MODE	Description	Wire connection
40057 (C16)	Controlling mode 1	1	<ul style="list-style-type: none"> Valve manual operation mode Control valve opening ratio by pressing ▲ ▼ on the panel 	
40057 (C16)	Controlling mode 2	2	<ul style="list-style-type: none"> Driving mode Driving by external 1-5V analog signal 	
40057 (C16)	Controlling mode 3	3	<ul style="list-style-type: none"> Temperature Control Mode By setting the targeted temperature, the controller will receive the temperature sensor signal to control the valve opening to meet the targeted temperature. 	

Notes:

- Using use the manual operation/Driving mode, please make sure compressor start/stop signal RUN is ON.
- Using driving mode, connect 1-5V external analog signal through pressure sensor port.

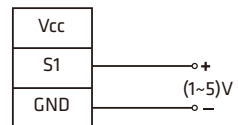

3.2 Refrigerant selection

In parameter list 4.Pr

Holding Register Address	Code	Description	Default value	Range
40062	d01	Refrigerant selection	5 (R507)	-1~35
			14 (R744-CO ₂)	



Note: For SEC631-HD and SEC641-HD, default value of d01 =14(R744). For SEC611-HD and SEC621-HD, default value of d01 =5 (R507).

There are a total of 36 refrigerants in the controller for selection

Code	Refrigerant	Code	Refrigerant	Code	Refrigerant	Code	Refrigerant		Refrigerant
-1(OFF)	Custom	7	R1234yf	15	R744A(N ₂ O)	23	R407H	31	R1270
0	R22	8	R290	16	R32	24	R454C	32	R1233zd(E)
1	R404A	9	R450A	17	R245fa	25	R455A	33	R1234ze(Z)
2	R410A	10	R513A	18	R23	26	R454B	34	R452C
3	R134A	11	R448A	19	R407A	27	R452B	35	R457A
4	R407C	12	R449A	20	R407F	28	R600a		
5	R507	13	R452A	21	R124	29	R600		
6	R1234ze(E)	14	R744(CO ₂)	22	R717	30	R454A		

3.3 Reset to factory settings

Holding Register Address	Code	Description	Default value	Range
40080	d19	Reset factory settings	0	0~999

Reset factory settings option is under 3.Pr menu. Under parameter setting status, press  to find parameter d19, enter password or back up password 913 and click , the factory settings will be resetted, and the controller will run again.

4. Parameter Table

4.1 Table1.Pr

Address	Description	Code	Unit	Interval	Min.	Max.	Default		
40001	Temperature / superheat setting value	A00	K	0.1	0.5	30.0	6.0		
40003	initial opening degree	A02	%	1	0	100	40		
40004	Initial opening durance time	A03	sec	1	0	600	10		
40005	P: Proportional increase	A04	%	0.1	0.1	99.9	1.0		
40006	I: Integral time	A05	sec	1	0	999	50		
40007	D: Differential coefficient time	A06	sec	1	0	999	30		
40008	Low superheat alarm mode	A07	0=N/A 1=Automatic reset				0		
40009	Low superheat alarm value	A08	K	0.1	0.5	30.0	0.5		
40010	Low superheat alarm delay time	A09	sec	1	1	300	15		
40011	Cancel low superheat alarm	A10	K	0.1	1	30.5	3.0		
40012	MoP Alarm Mode ¹⁾	A11	0=N/A 1=Automatic reset				1	0	
40013	MoP Alarm Value ²⁾	A12	bar	0.1	-1.0	50.0	99.9	9.0	38.7
40014	MoP Alarm Delay Time / Minute	A13	min	1	1	15	1		
40015	Cancel MoP alarm ³⁾	A14	bar	0.1	-1.0	50.0	99.9	8.0	36.7
40016	High superheat alarm mode	A15	0=N/A 1=Automatic reset				0		
40017	High Superheat alarm value	A16	K	1	10	40	30		
40018	High superheat alarm delay time/Minute	A17	min	1	1	600	3		
40019	Cancel high superheat alarm	A18	K	1	7	37	27		
40020	MoP valve closing ratio	A19	/	1	0	999	200		

- 1) For SEC611-HD and SEC621-HD, default value of MoP Alarm Mode =1.For SEC631-HD and SEC641-HD,default value of MoP Alarm Mode =0.
- 2) For SEC611-HD and SEC621-HD, Max. and default value of MoP Alarm Value =50.0 and 9.0.For SEC631-HD and SEC641-HD,Max. and default value of MoP Alarm value =99.9 and 38.7.
- 3) For SEC611-HD and SEC621-HD, Max. and default value of Cancel MoP alarm =50.0 and 8.0.For SEC631-HD and SEC641-HD,Max. and default value of Cancel MoP alarm =99.9 and 36.7.

4.2 Table 2.Pr

Address	Description	Code	Unit	Interval	Min.	Max.	Default
40021	Anti-freezing alarm mode	b00	0=N/A 1=Automatic Reset				0
40022	Anti-freezing alarm value	b01	°C	1	-40	40	0
40023	Anti-freezing alarm delay time/second	b02	sec	1	5	200	30
40024	Cancel anti-freezing alarm	b03	°C	1	-37	43	3
40025	Select pumpdown and delay time (Reserved)	b04	sec	1	-1	180	-1
40026	Pressure setting point to stop pumping down (Reserved)	b05	bar	0.1	-0.5	18.0	0.5
40027	Low pressure alarm mode	b06	0=N/A 1=Automatic Reset				0
40028	Low pressure alarm value	b07	bar	0.1	-0.8	17.7	0
40029	Low pressure alarm delay time / second	b08	sec	1	5	200	5
40030	Remove low pressure alarm	b09	bar	0.1	-0.5	18.0	0.3

4.3 Table 3.Pr

Address	Description	Code	Unit	Interval	Min.	Max.	Default
40041	EEV to have hold current or not	C00	0=Close 1=with hold current				0
40042	EEV Exciting mode(Shall power restart)	C01	0= (1-2phase exciting) 1= (2-2phase exciting)				0
40043	EEV total steps(Shall power restart)	C02	×10PLS	1	0	999	50
40044	EEV valve opening pulses(Shall power restart)	C03	PLS	1	0	999	30
40045	EEV exciting speed(Shall power restart)	C04	/	1	0	8	2
40051	Fixed EEV opening when defrosting*	C10	%	1	0	100	80 0

Address	Description	Code	Unit	Interval	Min.	Max.	Default
40052	EEV opening when sensor fails	C11	%	1	0	100	50
40053	Defrosting signal control enabled	C12	0= Disabled 1=Enabled				0
40056	start/stop signal control enabled	C15	0= Disabled 1=Enabled				0
40057	Controlling Mode (Shall power restart)	C16	0=Automatic superheat control 1=EEV Manual operation 2=Driving Mode 3=Temperature Controlling Mode				0
40058	Defrosting Control Mode	C17	0=external signal 1=Communication control				0
40059	Pressure transmitter type	C18	0=(0.5 ~ 3.5)V 1=(0.5 ~ 4.5)V				0

* The default value of Fixed EEV opening when defrosting is 80 for SEC611-HD and SEC621-HD, and 0 for SEC631-HD and SEC641-HD.

- 1) Because max. controller displayed value is 999, so EEV total steps value 50 means 500 steps.
- 2) EEV exciting speed 10(0)=10PPS ; 20(1)=20PPS ; 30(2)=30PPS ; 50(3)=50PPS ; 80(4)=80PPS ; 100(5)=100PPS ; 200(6)=200PPS ; 250(7)=2 50PPS ; 500(8)=500PPS;
- 3) Address 40052 EEV opening when sensor fails refers to the temperature sensor and pressure transducer.
- 4) Address 40053 defrosting signal control shall combine with Address 40058 defrost controlling mode to get enabled
- 5) Address 40056 start/stop signal shall combine with Address 40077 start/stop controlling mode to get enabled.

4.4 Table 4.Pr

Holding Register Address	Description	Code	Unit	Interval	Min.	Max.	Default
40062	Refrigerant ¹	d01	/	1	0	28	5 14
40063	Max. Pressure transmitter value ²	d02	bar	1	-1	99	20 60
40064	Min. pressure transmitter value ²	d03	bar	1	-1	99	-1 0
40065	Pressure transmitter offset correction	d04	bar	0.1	-9.9	9.9	0
40066	Temperature sensor offset correction	d05	°C	0.1	-19.9	19.9	0
40067	Password	d06	/	1	0	999	5
40070	EEV max. opening percentage	d09	%	1	0	100	100

Holding Register Address	Description	Code	Unit	Interval	Min.	Max.	Default
40071	EEV min. opening percentage	d10	%	1	0	100	0
40072	Sensor(pressure and temperature) input filtering time	d11	sec	0.1	1.0	99.9	1.0
40073	Forced EEV opening ratio	d12	%	0.1	-1 (OFF)	100.0	-1 (OFF)
40076	Display Mode	d15	0= Alternatively Display 1=Superheat 2=Evaporator outlet pressure 3=Expansion valve opening 4=Evaporator outlet temperature 5=Saturated temperature				0
40077	start/stop mode	d16	0=Normally open 1=start/stop signal control 2=Communication signal control				1
40078	MODBUS ID setting	d17	/	1	1	128	1
40079	Communication settings, baud rate, check bit, stop bit (Shall power restart)	d18	0=4800,NONE,1 1=9600,NONE,1 2=19200,NONE,1 3=38400,NONE,1 4=4800,NONE,2 5=9600,NONE,2 6=19200,NONE,2 7=38400,NONE,2 8=4800,EVEN,1 9=9600,EVEN,1 10=19200,EVEN,1 11=38400,EVEN,1 12=4800,EVEN,2 13=9600,EVEN,2 14=19200,EVEN,2 15=38400,EVEN,2 16=4800,ODD,1 17=9600,ODD,1 18=19200,ODD,1 19=38400,ODD,1 20=4800,ODD,2 21=9600,ODD,2 22=19200,ODD,2 23=38400,ODD,				1
40080	Reset factory setting	d19					0

- 1) For SEC611-HD and SEC621-HD,default value of d01 =5 (R507).For SEC631-HD and SEC641-HD,default value of d01 =14(R744).
- 2) Max. and min. pressure transmitter default value for SEC611-HD and SEC621-HD is 20 bar and -1 bar.Max. and min. pressure transmitter default value for SEC631-HD and SEC641-HD is 60 bar and 0 bar.
- 3) Address 40073 Forced EEV opening ratio is set at -1 which means communication control mode of EEV is disabled.
- 4) When resetting factory setting, set the corresponding parameters to be the password or 913, click  key to restart the controller. The resetting will be completed.
- 5) Only Parameter 1. Pr to 4.Pr will be resetted when resetting factory setting is completed.

4.5 Model Code (Read-only)

Address	Description	Code	Unit	Interval	Min.	Max.	Default
40085	Max. suction pressure AD	E04	/	1	0	999	662
40086	Min. suction pressure AD	E05	/	1	0	999	92
40092	Refrigerant user-defined parameters A1	/	91	A1 Min -20000 Max 20000 A2 Min -20000 Max 20000 A3 Min -20000 Max 20000 When the 40062 refrigerant is set to -1, enter custom mode. A1, A2, A3 are custom parameters, only supporting 485 communication settings.	(R449A) A1:9975 A2:-2020 A3:2424		
40093	Refrigerant user-defined parameters A2	/	92				
40094	Refrigerant user-defined parameters A3	/	93				

Note: If the pressure transducer is replaced, need to recalibrate the maximum and minimum AD of the new one.

5. Alarm Display

1. When the controller displays alarm, the alarm light will be on, and alternatively displays normal operation display interface and alarm display code.

Alarm display code list as below:

Code	Alarm information	Code	Alarm information
<i>STP</i> ¹⁾	RUN signal off	<i>nOP</i>	MoP high pressure alarm
<i>POP</i>	Pressure transmitter disconnection	<i>LoP</i>	LoP low pressure alarm
<i>PSt</i>	Pressure transmitter short circuit (for SEC611-HD/SEC621-HD) Cancel PSt alarm ²⁾ (for SEC631-HD/SEC641-HD)	<i>HSH</i>	High temperature/High superheat alarm
<i>tOP</i>	Temperature sensor not connected	<i>LSH</i>	Low temperature/Low superheat alarm
<i>tSt</i>	Temperature sensor short circuit	<i>FrE</i>	Low temperature frozen alarm

- 1) When the start/stop signal is disconnected and STP is displayed, it is not an alarm, but only a reminder of the operating status. When the system runs, the code disappears after the RUN start/stop signal line is closed.
- 2) High pressure of CO₂ may cause PSt false alarm, so this alarm is cancelled for SEC631-HD/SEC641-HD.

2. Address 40110 alarm bit

bit	15	14	13	12	11	10	9	8	7	6	5	4	3	2	1	0
						FrE	LSH	HSH	LoP	MoP			tSt	toP	PSt	PoP

Bit 0 indicates no alarm/protection; bit 1 indicates alarm/protection.

6. Communication status table

Add.	Function	Unit	Type	S	SEC6X1-HD	RS485 communication
40034	Present Superheat	K	Analog	INT 16		×10
40035	Present pressure	bar	Analog	INT 16	-1.0 ~ 99.0	×100
40036	EEV opening ratio	%	Analog	INT 16	0.0 ~ 100.0	×10
40037	Present temperature	°C	Analog	INT 16	-100.0 ~ 100.0	×10
40038	Present saturated temperature	°C	Analog	INT 16		×10
40073	EEV compulsory open ratio	%	Analog	INT 16	-1.0 ~ 100.0	×10
40101	Digital input status					
Bit0	Start/stop signal status	-	Digital	bit	0:STOP 1:RUN	
Bit1	Defrosting signal status	-	Digital	bit	0:OFF 1:ON	
40110	Alarm status	-	Analog	INT 16	Refer to below bit	
Bit0	Press. transmitter disconnection	-	Digital	bit	0:OFF 1:ON	
Bit1	Pressure transmitter short circuit (for SEC611-HD/SEC621-HD) Cancel Pst alarm ²⁾ (for SEC631-HD/SEC641-HD)	-	Digital	bit	0:OFF 1:ON	
Bit2	Temp. sensor disconnection	-	Digital	bit	0:OFF 1:ON	
Bit3	Temp. sensor short circuit	-	Digital	bit	0:OFF 1:ON	
Bit6	MoP alarm	-	Digital	bit	0:OFF 1:ON	
Bit7	LoP alarm	-	Digital	bit	0:OFF 1:ON	
Bit8	High superheat alarm	-	Digital	bit	0:OFF 1:ON	
Bit9	Low superheat alarm	-	Digital	bit	0:OFF 1:ON	
Bit10	Freezing Protection alarm	-	Digital	bit	0:OFF 1:ON	

7. Communication

1. Support standard RS485 Modbus RTU protocol (2-wire half-duplex), with a maximum of 31 cascades. It is recommended that the last controller be connected to the terminal with a resistance of 120 Ω.
2. Use twisted-pair shielded cables (2P x 24AWG is recommended) for communication cables. The shielded cables at both ends of the cables must be grounded separately.
- 3, when the host computer ID=255 or ID= [d17], it can achieve normal communication with the controller.
4. For the communication baud rate, the controller shall communicate according to 9600bps, 8, N, 1 within 4 seconds after being powered on. If it can communicate normally, the controller shall operate according to 9600bps, 8, N, 1 after 4 seconds. If the communication fails to be carried out at 9600bps, 8, N, 1 within 4 seconds, the controller will operate at the baud rate set by [d18] after 4 seconds.

8. Technical parameters

Item	Parameter	Item	Parameter
Operating voltage	220Vac(85V ~ 264V) 50/60Hz 25VA	Protection level	IP67
Switching signal	The start/stop and defrost switch signals are passive input	Installation method	Three M4x6 screws
Pressure transmitter	(0.5 ~ 3.5) Vdc or (0.5~4.5) Vdc, 5Vdc power	Operating temperature	-35°C~ 55°C
Temperature sensor	NTC 5KΩ(β=3970K), -40°C~ +105°C	Storage temperature	-40°C~ 60°C , 90% RH, non-condensing
Drive load	Unipolar 5-wire electronic expansion valve	Environmental pollution level	2
Anti-surge voltage	Class II	Insulation grade	II
Certification	CE,UKCA,EAC	EMC compliance	IEC61000-4-2, IEC61000-4-3 IEC61000-4-4, IEC 61000-4-5 IEC61000-4-6, IEC61000-4-11
Communication method	RS485, (Default) 9600, 8, N, 1		